

**STATE OF NEW JERSEY  
DEPARTMENT OF TRANSPORTATION  
TRENTON, NEW JERSEY 08625**

**METRIC SPECIFICATIONS FOR EIGHT PHASE TRAFFIC SIGNAL  
CONTROLLER ASSEMBLY**

N. J. Specification No. EBM-TSC-ITB-8

Effective Date: July 1, 2001

New Jersey Department of Transportation Specifications for a Microprocessor Based, Eight Phase Controller Assembly with Internal Time Base Coordination.

The purpose of these specifications is to describe minimum acceptable design and operating requirements for a microprocessor based, eight phase dual ring quad left fully traffic actuated traffic signal controller assembly with internal time base coordination.

**GENERAL - I**

- 1-1 The traffic controller assembly shall consist of a digital controller unit, signal conflict monitor, load switches, filters, flasher, detector card rack with power supplies, relays, connection wiring harnesses and other miscellaneous equipment in a complete and fully wired aluminum weatherproof cabinet. Serial numbers and date of manufacture for controllers shall be engraved into the frame of the controller. Controller modules and boards shall be permanently labeled with serial numbers that shall also be engraved into the frame of the controller.
- 1-2 The complete controller assembly shall conform to the requirements of current NEMA Standards No. TS-1, Sections 1, 2, 5, 6, 8, 10, 13, 14 and 15, except as amended and supplemented hereinafter. The manufacturer must supply certification which includes a copy of the test report by an independent technical laboratory as to equipment compliance with NEMA environmental standards in accordance with NEMA testing procedures.
- 1-3 Materials not specifically covered in these specifications shall be in accordance with the accepted standards of the National Electrical Manufacturers Association, The Underwriters Inc., The National Electrical Code, or the American Society for Testing and Materials.

**DEFINITIONS - II**

- 2-1 The NEMA Standards referred to in this specification shall be the current NEMA Standards Publication No. TS 1 entitled "Traffic Control Systems". All terms not defined in these specifications shall be as defined in Part 1 of the NEMA Standards.
- 2-2 Event time is the hour and minute of a 24 hour day. The function shall start at the first second of the minute assigned.

- 2-3 Day event is turning on or off an output circuit at a specified time. This output need not be external to the controller unit but its effect is the same, the controller will initiate the proper action.
- 2-4 Coordination plan shall be composed of a programmed cycle length, offset and cycle split.
- 2-5 Day program is any combination of day events. These events specify which coordination plan is selected.
- 2-6 Week program is any combination of seven day programs.
- 2-7 Year program is any combination of fifty-two week programs.
- 2-8 An exception day shall override the normal day program and utilize a specified day program.

### **CONTROLLER UNIT AND WIRING HARNESS - III**

- 3-1 A metal case suitable for shelf mounting shall be provided to house the controller unit. It shall be completely equipped and wired to provide eight phase dual ring quad left operation.
- 3-2 The controller unit shall be microprocessor based.
- 3-3 All modules shall utilize digital timing in the control logic and shall utilize line frequency as a base.
- 3-4 The controller unit shall be furnished with programmable read only memory (PROM) with permanent NEMA control program, as described in current NEMA TS-1 Sections 1, 2, 5, 6, 8, 10, 13, 14 and 15. EEPROM, or nonvolatile RAM shall be used to store program variables and sample real time data.
- 3-5 A menu driven format shall be utilized. The menu format shall preclude the need for programming cards or tables. All data shall be entered utilizing a tactile feedback keyboard supplied on each controller.
- 3-6 All ROM's, EEPROM's, nonvolatile RAM's and microprocessor shall be installed in IC sockets. As an alternate, IC's that contain software programming may be installed without sockets if the IC's are installed on a removable card. If a card is utilized, one spare card shall be provided with the first unit supplied under each contract or proposal to which this specification applies. One additional card shall be provided with every five units supplied thereafter under each contract.
- 3-7 The controller unit shall be equipped for and be capable of immediate eight phase semi-actuated, fully actuated, and volume density operations. All phases must be equipped with concurrent pedestrian timing. All liquid crystal displays and keyboards necessary to achieve programming requirements shall be mounted on the front panel of the unit.

- 3-8 In addition to the eight phase dual ring quad left operation specified hereinbefore, the controller unit shall be equipped and wired for immediate use of sequences depicted in diagram #1 of the specifications. Sequence #3 shall only be supplied when required to provide the timing sequence in the contract documents to which this specification applies.
- 3-9 The controller unit must be capable of omitting any phase, by programming a "no phase" or a phase omit through the keyboard entry. This phase omit feature shall omit a phase during start-up and normal operation.
- 3-10 The maximum DC voltage generated within the controller unit shall not exceed 50 volts.
- 3-11 If extender boards are necessary for testing or repair, two extender boards for each type of printed circuit board shall be provided with the first unit supplied under each contract or proposal to which this specification applies. One additional extender board for each type of printed circuit board shall be provided with every five units supplied thereafter under each contract.
- 3-12 An internal diagnostic routine shall be incorporated in the software program. It shall be exercised using the resident processor and shall be capable of checking all memory elements. When a fault is detected an appropriate message shall be displayed.
- 3-13 A 25 pin RS 232C connector for the printer port shall be provided for interconnecting to a printer. It shall transmit (data, letters, headings, etc.) to a printer at 1200 baud. The printer shall be able to receive ASCII coded data. All controller unit timing, operational data, pre-emption data, coordination program data, time base data, system data, and reports shall be transmitted to the printer. The unit to printer transmissions shall not interrupt normal controller unit operation.
- 3-14 Total solid state circuitry shall be employed in the controller unit. All components shall be identified by the industry standard except manufacturer's LSI Devices.
- 3-15 Liquid crystal displays shall be utilized. The display shall have a backlite for viewing at night. Incandescent indicator lights are not acceptable. As a minimum the model number and software version shall be displayed.
- 3-16 In addition to the minimum indicators required by NEMA standards, Section 14, a display menu shall be provided for selection of MAX II green timing.
- 3-17 All programmable functions shall be performed by keyboard. No foil deletions will be permitted to achieve any programming requirements.
- 3-18 If ROM replacement is utilized to obtain the four required sequences of operation as hereinbefore specified, the ROM must be supplied and stored within the controller. All ROM's utilized for other sequences of operation, shall be installed in zero insertion force IC sockets. If additional ROM's are supplied external to unit, the sockets with ROM's installed must be shipped in static free foam. Each ROM supplied shall be labeled to identify the sequence of operation which it provides.

- 3-19 Selection of steady or flashing "Walk" operation shall be programmable by keyboard entry for each phase.
- 3-20 The controller unit shall be capable of being programmed to start or initialize in accordance with NEMA TS 1-14.3.4.1. Unless otherwise specified in the contract documents, controller units shall be programmed to initialize in artery green.
- 3-21 Manual control operation shall utilize Manual Control Enable and Interval Advance.
- 3-22 All controller units shall contain all necessary wiring and circuitry to produce eight internally generated overlaps (4 NEMA and 4 unused peds). Program options shall be provided to allow the timing of yellow change and red clearance to be determined by the terminating parent phase and by independent adjustment for each overlap. Independent adjustment programs shall also provide for green extension. Overlaps shall be programmable by keyboard.
- 3-23 Programs shall be provided that allow overlap green and yellow outputs to be suppressed, switched to its red state, as determined by the following conditions:
- A. If a suppression phase is green, the overlap will remain red.
  - B. If in a suppression phase and the phase next is a suppression phase, the overlap will remain red.
  - C. In all other conditions, the suppression phase does not alter the overlap. Variations in program, which result in the same operation outlined above, will be permitted.
- 3-24 All controller units shall be capable of being programmed for dual or single entry mode of operation.
- 3-25 A guaranteed three second minimum Yellow Clearance shall be provided.
- 3-26 Internal pre-emption shall be incorporated into the controller program. All data for pre-emption shall be entered through the keyboard. The unit shall provide a minimum of 4 pre-emption sequences, with one priority sequence. A minimum of one sequence shall have keyboard inputs for memory on/or memory off.

The following shall be the minimum acceptable parameters for each pre-emption routine:

**PARAMETER DEFINITION**

Delay Time Delay prior to start of pre-emption

Hold/Inhibit Time Time to hold active phase or to omit all other phases

Min/Walk/PCL Time Selects new or aborts active Min/Walk/PCL time

EVP/Hold Phase(s) Selects phase(s) to service pre-emption

Dwell Time Guaranteed pre-emption time

Exit Calls Calls phase(s) to be called and serviced following pre-emption

- 3-27 An input and the circuitry required to accomplish MUTCD flash shall be incorporated into the controller unit.
- 3-28 Harnesses for "A", "B", "C" and "D" Connectors, and Monitor Harnesses shall have a nylon braided expandable self-fitting cable sleeving.
- 3-29 Cables shall be used for interfacing between all panels including police panel. Cable shall have a PVC Jacket rated for 300 volts. The conductors shall be minimum 18 AWG Stranded Annealed Copper Wire with PVC Insulation Rated for 300 volts minimum and shall be rated for use at 105 °C.
- 3-30 Each detector input shall be capable of being programmed for stretch and delay timing. Program shall also include inhibit of stretch and delay during selected phases and or intervals.
- 3-31 It shall be possible to upload/download all controller program data through an industry standard RS232C I/O port with a laptop computer. It shall also be possible to edit all controller programs stored within the laptop computer without the need to be connected to a controller unit (stand along capability).

**COORDINATION TIMING AND FUNCTIONAL REQUIREMENTS - IV**

- 4-1 The controller unit shall be capable of internal time base coordination. The internal coordinators, when installed at a group of intersections, shall provide a coordinated system without the use of interconnecting cables. Each internal coordinator shall provide the synchronizing signals from an internally stored coordination plan, using a precise clock as reference. A battery or capacitive backup voltage source shall be provided with the TBC circuitry. In the battery backup mode time is to be maintained within  $\pm 0.005\%$ .
- 4-2 The coordination plan shall be, as a minimum, based on a time of the year program. The time of the year shall be set to the time of day, day of week, and week of the year.
- 4-3 The controller unit shall display, as a minimum, the day of week, hour, minutes and seconds, using military time. The controller unit shall, upon request from the keyboard,

display output status and coordination plan data. The coordination plan data shall be capable of being scanned without affecting the plan in operation.

- 4-4 The internal coordinator shall automatically adjust for daylight savings time including automatic annual adjustments. This requirement shall be accomplished by a programmable function, programmed to the first Sunday in April and the last Sunday in October. As an alternate to this requirement the manufacturer may accomplish this function in ROM.
- 4-5 The internal coordinator shall be capable of implementing coordination plans containing, as a minimum:

- \*1) Four cycles
- \*2) Four splits per cycle (Total 16 Splits)
- \*3) Three offsets per cycle (Total 12 Offsets)
- 4) Eight permissive periods per split
- 5) Eight force-offs per split
- 6) One pedestrian permissive period per permissive period
- 7) One dwell period per cycle

\* Sixteen timing plans consisting of one cycle length per timing plan; one split per timing plan; and three offsets per timing plan may be provided in place of parameters a, b, c above, or forty-eight timing plans, each consisting of its own cycle length, split and offset may be provided. However, an input/output map program must be provided to provide correlation between the two methods.

- 4-6 The controller unit shall contain memory for storage of the coordination plans. The programming of this memory shall be accomplished through data entry utilizing the keyboard. All data shall be displayed for verification before it is entered.
- 4-7 The coordination plans shall be programmable in one second increments to any value between the following limits:

	<u>FUNCTION</u>	<u>SECONDS</u>
1)	Cycle Length	30 - 255
2)	Offset	0 - 255*
3)	Splits	0 - 255*
4)	Maximum Dwell	0 - 255*
5)	Permissive Periods	0 - 255*

\* This function may be a percentage of the background cycle.

- 4-8 The internal coordinator shall automatically "smooth" the change in offset and cycle length when a change is required by a new coordination program. The method of smoothing shall comply with Paragraph 4-9 or shall be programmable and the options shall include:

**DWELL:** The internal coordinator shall not permit the controller unit to dwell at its dwell point by more than the programmed period of time until offset is reestablished.

**SMOOTH WAY:** The internal coordinator shall shorten or extend the cycle length by no more than 50% until offset is re-established.

- 4-9 The internal coordinator shall automatically "smooth" the change in offset and cycle length when a change is required by a new coordination program. The method of smoothing shall be that the internal coordination will select a background cycle based on supplied minimum and maximum cycle lengths. The cycle length selected will achieve the new offset in the smallest number of cycles possible and then implement the background cycle required by the coordination plan in effect. The smooth way method shall be utilized unless otherwise specified in the contract documents.
- 4-10 Transfer from one cycle to another shall occur at the end of the cycle in effect.
- 4-11 The internal coordinator shall be capable of having the phase association for the force-offs, and permissive periods programmable from the keyboard.
- 4-12 The force-off function shall terminate the right-of-way on the programmed phase or phases, and shall be maintained until the green of that phase terminates.
- 4-13 The internal coordinator shall be capable of providing permissive periods as follows:
- A. During each permissive period, the coordinator will allow the controller to leave the coordinated phase(s) and selectively respond to vehicle and/or pedestrian calls from allowable phase(s). The allowable phase(s) for each permissive period shall be programmable.
  - B. The start and end of vehicle permissive periods shall be programmable through the keyboard. A pedestrian permissive period shall start with the vehicle permissive period for the associated phase. The end of the pedestrian permissive period shall be determined by a duration that is programmed with the keyboard.
  - C. Permissive periods shall provide for the release and application of phase omits as programmed.
  - D. Once the coordinated phase(s) has terminated, all internal omits associated with permissive shall be removed and the controller permitted to service the remaining phase in a normal manner. The controller unit shall not yield on subsequent permissive periods in the same cycle.
- 4-14 As an alternate to Paragraphs 4-11, 4-12 and 4-13, the coordinator may "automatically" provide for servicing and terminating phases through internal calculations based on the minimum green intervals, vehicle clearances, pedestrian walk and clearance intervals and the minimum and maximum cycle lengths supplied. Controllers utilizing automatic calculations shall provide an additional program to allow for a simple yield type of

coordinated operation. That is, one release period occurring for approximately 3% of the cycle whereas the coordinated phase(s) shall terminate and opposing calls are allowed to be serviced.

- 4-15 A "D" multi-terminal receptacle shall be mounted on the front of the controller unit. The inputs and outputs for the coordination shall be wired through this receptacle. A multi-terminal plug shall be provided to mate with the receptacle. The plug shall have all active functions completely wired and terminated on a sub panel in the location shown on Drawing No. P-23.
- 4-16 The controller shall have, as a minimum sufficient output combinations to indicate:
- A. Cycle 1 thru 4
  - B. Offset 1 thru 3
  - C. Split 1 thru 4
- 4-17 The controller shall have, as a minimum sufficient input combinations to call the following:
- A. Flash
  - B. Cycle 1 thru 4
  - C. Offset 1 thru 3
  - D. Split 1 thru 4
- 4-18 When the controller unit is used as a secondary controller the internal time of day coordination plan shall be in effect during the following conditions:
- A. Loss of system input or communications.
  - B. When directed by master coordinator or on street master unit to select a particular coordination plan.
  - C. When manually selected using the keyboard.
- 4-19 When the controller unit is used as a secondary controller, free operation shall be in effect during the following conditions:
- A. When pre-emption is in effect.
  - B. When flash is in effect.
  - C. During manual operation
- 4-20 The data base for the TBC shall be capable of supporting at least 10 day plans with no less than 150 event times distributed over the 10 day plans, 8 week plans assignable



throughout the 52 weeks of the year, and at least 10 exception days. The exception day program may select "special days" or relate to an individual "normal" day plan.

- 4-21 Sync reference time shall be programmable or preset to midnight in order to provide a common point in time to reference the sync pulse for the cycle timers.
- 4-22 All unused green time from the actuated phases which do not time to their maximum or are skipped shall revert to the beginning of highway green. If the programmed pedestrian time exceeds the programmed split value or max green time, the amount of time exceeded shall be subtracted only from the coordinated phase (highway green).
- 4-23 The coordination plan shall be structured to allow the selection of cycle/offset/split combinations from the T.O.D. program or hardwire interconnect as indicated below:

C1/01/(S1)	C2/01(4)/ S1(5)	C3/01(7)/ SP1(9)	C4/01(10)/SP1(13)
(S2)	S2(6)	SP2(10)	SP2(14)
(S3)	S3(7)	SP3(11)	SP3(15)
(S4)	S4(8)	SP4(12)	SP4(16)
C1/02/(S1)	C2/02(5)/S1(5)	C3/02(8)/SP1(9)	C4/02(11)/SP1(13)
(S2)	S2(6)	SP2(10)	SP2(14)
(S3)	S3(7)	SP3(11)	SP3(15)
(S4)	S4(8)	SP4(12)	SP4(16)
C1/03/(S1)	C2/03(6)/S1(5)	C3/03(9)/SP1(9)	C4/03(12)/SP1(13)
(S2)	S2(6)	SP2(10)	SP2(14)
(S3)	S3(7)	SP3(11)	SP3(15)
(S4)	S4(8)	SP4(12)	SP4(16)

### **DATA TRANSFER REQUIREMENTS - V**

- 5-1 The internal coordinator shall be capable of transferring program (controller, coordination, time clock) data to another coordinator via the controller unit "D" connector or RS 232 connectors.
- 5-2 A cable shall be provided for the purpose of transferring coordination data. One cable shall be provided with the first unit supplied under each contract or proposal to which this specification applies. An additional cable shall be provided with every five units supplied thereafter under each contract.

### **LOAD SWITCHES - VI**

- 6-1 All load switches shall be the three circuit type conforming to the requirements of NEMA TS-1, Section 10, and be equipped with 3 input indicator lights.
- 6-2 All load switches shall utilize optically isolated encapsulated modular solid state relays. Discrete components on circuit boards are not acceptable.

- 6-3 Each optically isolated encapsulated relay utilized in the load switch pack shall have a minimum rating of 25 amps at 120 volts AC.
- 6-4 A minimum of eight three circuit load switches shall be furnished. If additional load switches are necessary to provide the timing and sequence of operation required by the contract to which this specification applies, the additional load switches must be furnished.

### **CONFLICT MONITOR - VII**

- 7-1 The conflict monitor shall be a stand alone Type 12 and conform totally with the requirements of current NEMA Standard TS-1, Section 6.
- 7-2 All pins of the connector plug shall be wired and terminated on a cabinet mounted terminal block per Section 8 of this specification. Channel assignments shall be wired to their corresponding phase. For example, channel 1 to phase 1, channel 8 to phase 8, overlap A thru overlap D shall be channel 9 thru channel 12 respectively.
- 7-3 Indicator lights or liquid crystal displays shall be provided for all channels in order to display the active channels.
- 7-4 The start delay relay shall be utilized to provide power to the controller mechanism.
- 7-5 A programmed diagnostic package must be available for use with the monitor unit, but will not be required to be supplied unless otherwise specified in the contract to which this specification applies. The program must be capable of checking all monitor operations. All internal wiring, connections and integrated circuit socket for the diagnostic chip must be furnished and installed in the unit for immediate use.

### **CABINET AUXILIARY EQUIPMENT - VIII**

- 8-1 The enclosed controller mechanism shall be housed in an aluminum cabinet (Grade 50-52-H32) fabricated in accordance with sketch attached to and forming a part of this specification, identified as Drawing No. P-21. Dimensions of the cabinet furnished must meet or exceed all minimum dimensions shown. Cabinets not conforming will not be approved. The cabinets shall be of adequate size to house the maximum size eight phase controller as specified by NEMA.
- 8-2 All surfaces of the cabinet shall be clean, free of holes or blemishes, smooth without burrs and with exterior corners rounded. The cabinet shall not be painted.
- 8-3 A thermostatically controlled fan with a minimum 2.83 cubic meters per minute airflow for ventilation screened against the entrance of dust and foreign matter, shall be furnished and mounted in the top of the cabinet and completely wired and interconnected.
- 8-4 A replaceable 305 by 406 by 25 millimeter filter for the incoming air shall be provided.

- 8-5 Sixteen load switch bases shall be provided and wired to accommodate the eight phase signal operation, four programmable overlaps and four programmable pedestrian indications. Stacking of load switch bases is not permitted.
- 8-6 A silk screen or permanent label of the inputs and outputs shall be provided on at least one vehicle and one pedestrian load switch base, as shown on the attached diagram #3. All load switch bases shall also be identified as to the phase or operation for which they are programmed. If permanent labels are used, a sample must be submitted before acceptance. All lettering on all panels shall be no smaller than 2 millimeters in height.
- 8-7 In addition to the signal load relays and monitor unit, a solid state two circuit flasher with six transfer relays (Magnecraft W2IACPX-2, Midtext Type 136-62T200, or AEMCO Type 136-4995) shall be furnished and mounted in the cabinet and completely wired. The flasher shall conform to NEMA TS-1, Section 8, and shall be a Type 3 flasher. The flasher shall be equipped with Neon or LED indicators representative of the flasher outputs. Transfer relays shall be rated at 20 amps per circuit.
- 8-8 Flash transfer relays shall be so wired as to be de-energized for flashing operation and shall be in close proximity to load relays, flashers, and field terminals. Flasher outputs and connections for transfer relays shall be provided and terminated on terminal blocks for programming of Flash 1 or Flash 2 outputs. The load on both circuits of the flasher should always be balanced. Unless otherwise specified in the contract to which the specification applies, phase, overlap and flash programming shall not be completed.
- 8-9 The main panel shall be capable of dropping down in order to access the back of the panel without removal and interference of any cabinet components.
- 8-10 The following components shall be provided and mounted on a sub-panel protected by a polycarbonate cover isolated from the main back panel, and completely wired, through its own terminal block. The terminal block should be easily accessible, and as described herein for signal field terminal blocks. Panel shall conform to diagram #5. All panels shall be a minimum of 3 millimeter thick aluminum.
- A. A mercury plunger type signal bus relay shall be installed through which the AC plus to the signal bus shall be provided when the relay is energized.
  - B. A plug-in "power off" relay with a clear polycarbonate dust cover. This relay, Struthers-Dunn Type A283XBXC1, or Potter and Bannfield Type, KUP14A11 or OMRON Type MK20-2, shall be of such design and so connected that if the power is interrupted, the relay shall de-energize and remain de-energized until reset, denoting an interruption, but will allow the control mechanism to return to operation when current is restored. This relay shall be reset manually only, and is to be of the two-pole double-throw type, one pole for resetting and one pole for the installation of a tell-tale miniature lamp which shall be furnished with the equipment.
  - C. The cabinet control wiring and control equipment shall be protected with a circuit breaker of proper rating located within the controller cabinet. A separate circuit

breaker shall be provided for the flash operation. Breaker type should be comparable to an E frame circuit breaker.

- D. A 120 volt AC single phase surge protector shall be installed as a precautionary measure against possible damage resulting from voltage surges on all incoming power lines. The 120 volt AC single phase surge protector shall incorporate a series choke at a maximum clamp voltage of 340 volts at 20 kiloamps with 5 nanosecond response. In addition, the surge protector shall have the capability of removing high energy surges and block high speed transients. The surge protector shall comply with the following specifications:

Peak Current: 20 000 amps (8x20 microsecond waveshape)  
Occurrences: 20 times at peak current  
Minimum Series Inductance: 200 microhenries  
Continuous Series Current: 10 amps  
Temperature Range: -40 °C to +85 °C

If required by the contract to which the specification applies, a surrestor shall be installed for all communication lines. The surrestor shall comply with the following specifications

Peak Current: 10 kiloamps (8x20 microsecond waveshape)  
Occurrences at 2 000 amps: 50 typical  
Response Time: < 5 nanoseconds  
Voltage Clamp: 8, 12, 20, 30 or special  
Series Resistance: 24 ohms total  
Operating Temperature: -40 °C to +85 °C  
Primary Protector: Three element gas tube, 10 kiloamps, 8x20  
microseconds per side  
Secondary Protector: Solid state clamps, 1.5 kilowatt minimum

All components, circuits and accessories considered necessary by the manufacturer to adequately protect the controller assembly and associated equipment from damage due to voltage surge shall be furnished. All devices shall be readily accessible for ease of replacement and not mounted behind any panel or enclosure.

- E. A radio interference filter. This filter shall be connected as to completely filter controller and auxiliary equipment, and shall have a minimum rating of 50 amps.
- F. Three copper ground bars with brass terminal bolts capable of handling #10 wire and having a minimum of 12 terminal connecting points shall be provided and labeled AC-, chassis and logic ground.

AC-, chassis and logic ground shall be isolated from each other throughout the assembly, including any auxiliary sub-panels. AC- and logic ground bars shall be mounted on insulators.

- G. An additional fourth copper ground bar mounted on insulators shall also be provided on the lower portion of the power panel, having a minimum of 24 terminals, electrically connected to AC- for field wiring.
  - H. Spacing between ground bars on the power panel shall not be less than 38 millimeters apart.
  - I. All connections between the power panel and any other panel shall only be through terminal blocks on each panel.
  - J. All subpanel power cables shall terminate directly to the power panel not to adjacent subpanels or to the backpanel.
  - K. A UL approved convenience outlet shall be installed, and it shall be required to have ground fault protection incorporated.
  - L. Terminal block for incoming power shall be a two terminal block rated at 50 amps and shall have a minimum barrier height of 19 millimeters and utilize M5 x 8 screws.
- 8-11 A one piece detector panel shall always be provided and shall conform to the attached diagram #4. All panels shall be a minimum of 3 millimeter thick aluminum. The detector rack wiring harnesses shall be terminated on this panel. Terminal blocks utilized shall be of the double row barrier type rated at 30 amps and of one solid unit. Terminal blocks shall be spaced 6 millimeters apart. Two pedestrian isolation circuits designed for a 12 volts AC input shall be supplied.
- 8-12 All conductors, including spares, from the controller unit, conflict monitor, load switches and all other auxiliary equipment shall be terminated on interface terminal blocks in the cabinet and be identified. All terminal connections shall be marked with a number and NEMA function. All labeling must be silk screen or permanent labels. If permanent labels are used, a sample must be submitted for acceptance.
- 8-13 The following items shall be installed on a panel behind the small door, in the recess of the door-in-door.
- A. Switch for automatic/manual operation.
  - \*B. Switch for automatic/flashing operation.
  - \*C. Switch for signals only "on" and "off".
  - D. A manual cord consisting of 1.8 meters of rubber insulated cord and a weather-proof normally open momentary contact.
- \*During signal off and flashing operation from the Police panel, the controller shall not be de-energized. An external restart shall be applied and held during this operation. Signal flash has priority over signal off.

- 8-14 The outgoing traffic controller signal circuits shall be of the same polarity as the line side of the power supply; the common return of the signal circuits shall be of the same polarity as the ground side of the power.
- 8-15 Field terminals utilized in the cabinet assembly shall be of the double row high type barrier blocks. They shall be rated at 50 amps and shall have a minimum barrier height of 16 millimeters and shall utilize M4 x 8 screws as a minimum. Field terminal blocks shall be mounted horizontally at a minimum of 250 millimeters from the bottom of the cabinet. At each output for connection of signal wire on the field terminal blocks, a lug connector with spade and set screw, shall be attached. The lug connector shall be UL listed, intended to hold up to 6 #14 AWG individual wires. The lug connectors shall be capable of handling #14 - #6 AWG wire. Thirty amp terminal blocks with M4 screws shall be utilized for flash programming. All connections to the field terminal blocks from load switch bases and flash transfer relay bases shall be made with vinyl insulated spade connectors. Soldering of any connections to field terminal blocks shall not be permitted.
- 8-16 Sufficient copper ground bars shall be supplied to terminate spare field conductors (maximum 3 conductors per terminal), as required by the contract which this specification applies.
- 8-17 All cabinet doors shall incorporate hinges and hinge pins utilizing stainless steel. Fastening of hinges to doors and cabinets shall be made using stainless steel pop-rivets or stainless steel nuts and bolts. Welding of hinges to cabinets and doors shall not be permitted.
- 8-18 The use of printed circuit boards in any part of the cabinet design will not be permitted.
- 8-19 All MS connectors to controller and monitor shall be complete with MS cable clamp. Example: the amphenol MS clamp type MS3057A.
- 8-20 A fluorescent fixture supplied with a lens or shield and a 20 watt, Type T-12, 430 milliamp lamp and rapid start, high power factor ballast shall be supplied and installed in the top front portion of the cabinet. A switch shall be installed on the inside of the cabinet door on or near the police panel so that the lamp can be extinguished manually.
- 8-21 Cabinet layout shall be designed, as per drawing number P-23.
- 8-22 As an alternate to copper ground bar, a tin plated ground bar utilizing M8 x 1 x 10 screws shall be utilized. The tin plated ground bar shall be capable of handling #14-4 AL-CU wire and have a minimum of 12 connecting points.
- 8-23 The detector card rack shall be made of anodized aluminum and be capable of accommodating standard 114 by 175 millimeter detector and power supply cards.
- 8-24 The detector card rack shall be positively fasten to the upper shelf of the controller cabinet utilizing a method for easy removal.

- 8-25 Twenty-two pin Cinch Jones 50-44A-30M connectors designed for keys between contacts B and C, M and N shall be provided for dual power supplies and eight +24 volt DC, 130 milliamp (maximum) detector cards.
- 8-26 The interface harness connections at the loop detector card rack shall either be soldered or mechanically installed. If mechanically installed, some positive method of locking the connector to the rack shall be provided. The conductors for the interface harness shall be 22 AWG stranded annealed copper wire, with insulation rated for 300 volts. The wire in the harness shall be individually twisted pairs for loop inputs .
- 8-27 Dual power supplies to power eight +24 volts DC, 130 milliamp (maximum) detector cards shall be supplied per controller assembly.
- 8-28 The power supplies for the detector card rack shall have a regulated output voltage.

### **INSTRUCTIONS AND GUARANTEES - IX**

- 9-1 One set of complete schematics and maintenance manual including detailed theory of operation of the controller unit, monitor and auxiliary equipment shall be supplied with each controller assembly furnished.
- 9-2 One reproducible blackline Diazo mylar (0.1 millimeter thick) A1 size (594 by 841 millimeters) and two prints of the schematic wiring diagram for the cabinet back panel and auxiliary equipment shall be supplied with each controller assembly furnished. The schematic wiring diagram shall contain the information in at least 6 millimeter lettering.
- A. Contract and bid dated.
  - B. Model and number of all equipment.
  - C. Intersection location.\*

When not applicable, the diagram shall have the work "location" and a blank space where the intersection can be added.

- 9-3 No changes or substitutions in these requirements will be acceptable unless authorized in writing. Inquiries regarding this specification shall be addressed to the Manager, Office of Traffic Signal and Safety Engineering, New Jersey Department of Transportation, P.O. Box 613, 1035 Parkway Avenue, Trenton, New Jersey 08625.
- 9-4 The complete control and auxiliary equipment shall carry a two (2) year guarantee from the date of delivery against any imperfections in workmanship or materials. Any tests or repairs made by a manufacturer or representative shall be documented on the New Jersey Department of Transportation "Equipment Failure Analysis and Report Form" and returned with units when warranty repaired. The Department will attach a copy of this form to all returned equipment. This documentation shall include an explanation of the exact repairs made and identification of parts replaced by part number and circuit number. All warranty repairs must be made within thirty days upon receiving equipment.

- 9-5 The company agrees upon the request of the Manager, Office of Traffic Signal and Safety Engineering to deliver to the Office, a sample of the control equipment to be supplied in compliance with these specifications for inspection and test before acceptance. After completion of the test, the sample shall be returned.
- 9-6 The company shall furnish any and all equipment which they deem necessary for safe and reliable field operation of the control equipment.
- 9-7 Controllers furnished under this specification must be current production equipment and of recent manufacturer, identical models of which are field operational. Untried or prototype units shall not be considered for acceptance.
- 9-8 In the event of a software revision made to the controller program after the unit has been tested and approved according to this specification. The supplier must submit to the Office of Traffic Signal and Safety Engineering a letter from the manufacturer explaining the changes, and the reasons for the changes.

### **STATE BID PURCHASED EQUIPMENT - X**

The following section applies only to equipment procured through bid for direct State purchase:

- 10-1 Delivery of all controller assemblies and coordinators must be complete within 6 months of receipt of order.
- 10-2 All controller assemblies are to be shipped complete and no payment will be released except for complete units.
- 10-3 The State reserves the right to increase the quantity of equipment ordered at time of bid award.
- 10-4 The unit price bid for each eight phase controller assembly shall include one complete set of diagnostics for controller unit and signal conflict monitor (one set for the entire 8 phase order) and shall be delivered within 6 months of receipt of this order.
- 10-5 The company shall deliver a complete controller assembly to the Bureau of Maintenance Engineering, 999 Parkway Avenue, Trenton, N.J. in compliance with these specifications for inspection and test before acceptance. The complete assembly must be delivered within one month of the award of the contract. Failure to deliver a complete assembly within the one month time frame shall result in the rejection of the company's bid and award shall be made to the next low bidder. If during testing the controller assembly is found to be in non-compliance with our specifications, written notice will be sent to the company.
- 10-6 Within four weeks of the receipt of this written notification, the company must resubmit the unit for testing. If the unit fails this testing, the company's bid shall be rejected and award shall be made to the next low bidder.



- 10-7 The unit price bid for each two phase and eight phase controller assembly shall include all costs associated with the providing of a formal two day minimum training program in maintenance techniques of the respective controller unit. Each two day class shall be conducted at the Department of Transportation Headquarters for approximately 20 people and shall include an explanation of circuitry and trouble shooting procedures.
- 10-8 The "D" Connector with subpanel shall not be supplied.
- 10-9 Cabinet door shall be fitted for CCL Lock #15481RS but not supplied.
- 10-10 Two Adapter Brackets as per Drawing No. P-30 shall be supplied with the first 20 percent of the bid quantity.

EIGHT PHASE SEQUENTIAL OPERATION  
SEQUENCE #1

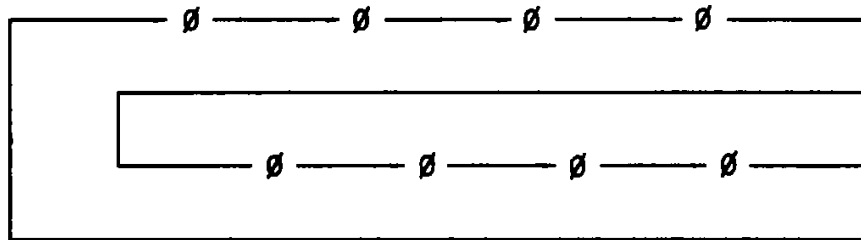

SEQUENCE #2

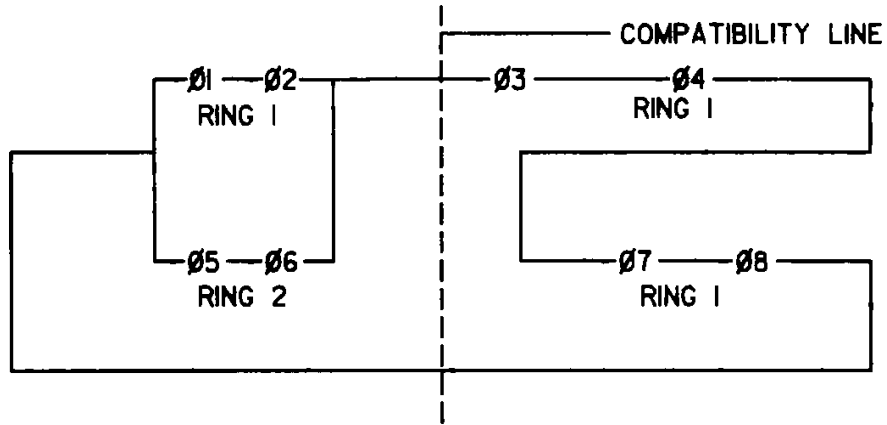

SEQUENCE #3

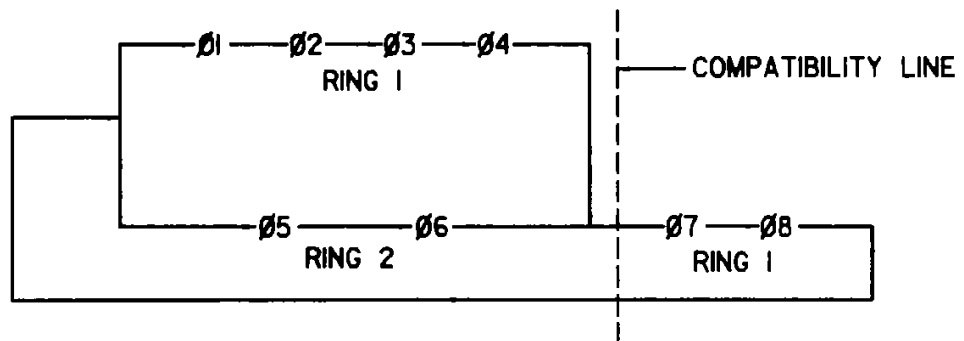

DIAGRAM No. 1

### SILK SCREEN PRINTS IDENTIFYING INPUTS AND OUTPUTS OF PEDESTRIAN AND VEHICLE LOAD SWITCHES

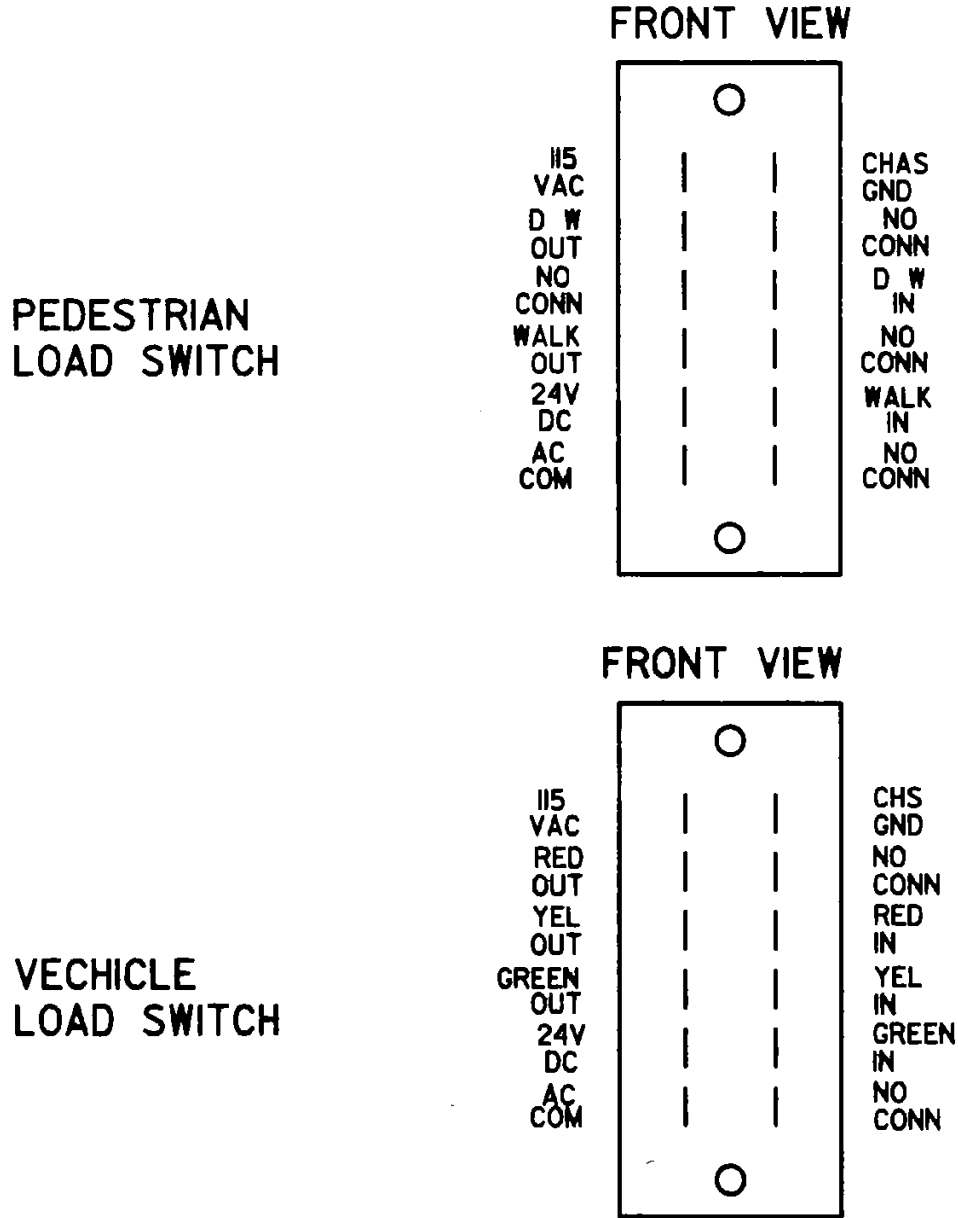
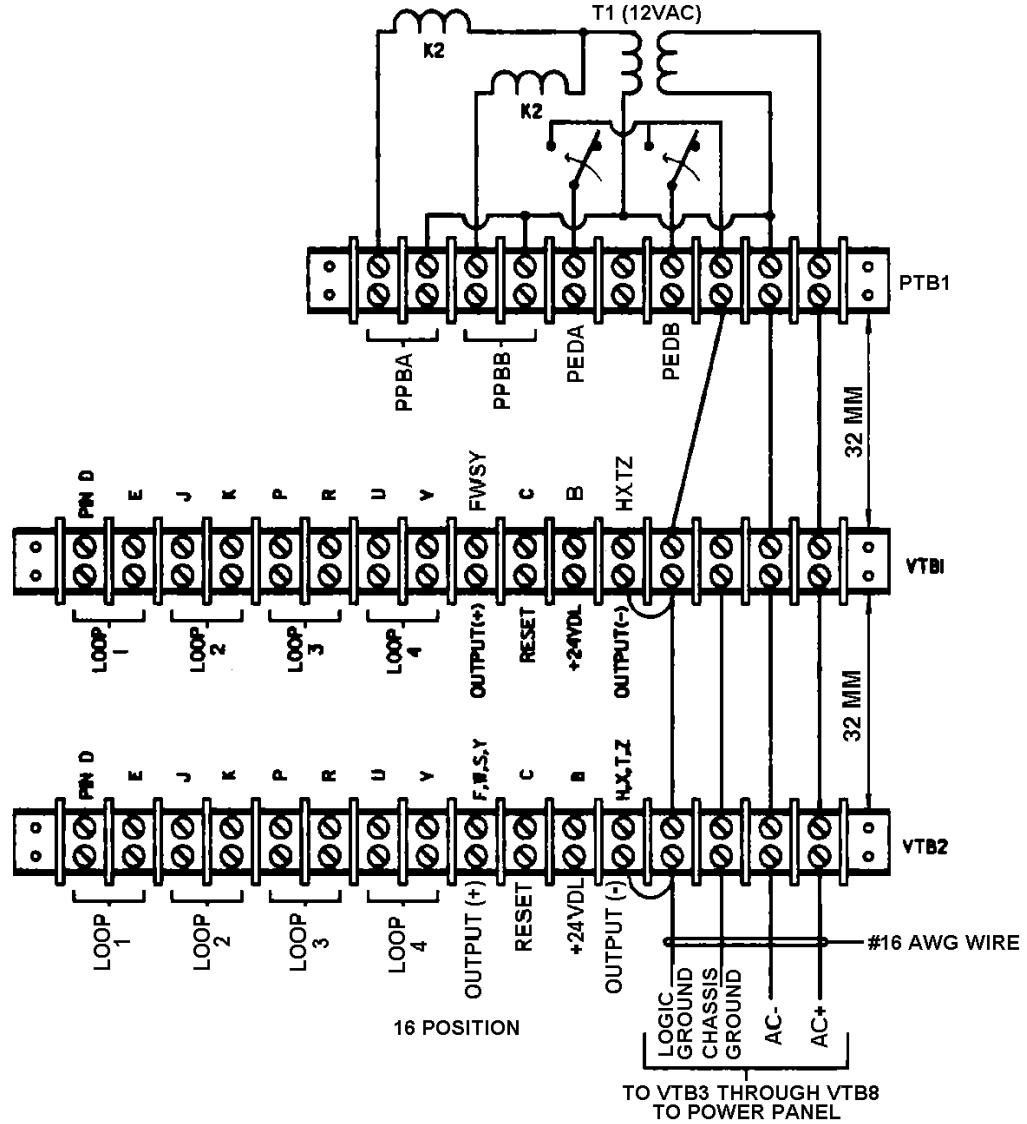

DIAGRAM No. 3

**DETECTOR PANEL**

**NOTES:**

1. A MINIMUM OF 8 VEHICLE DETECTOR BLOCKS SHALL BE SUPPLIED. THESE BLOCKS SHALL BE RATED AT 30 AMPS MINIMUM.
2. TWO GROUND BARS WITH BRASS TERMINAL BOLTS CAPABLE OF HANDLING #10 WIRES AND HAVING A MINIMUM OF 12 TERMINAL CONNECTING POINTS SHALL BE PROVIDED BELOW THIS PANEL FOR SPARE FIELD WIRES.



**DIAGRAM NO. 4**

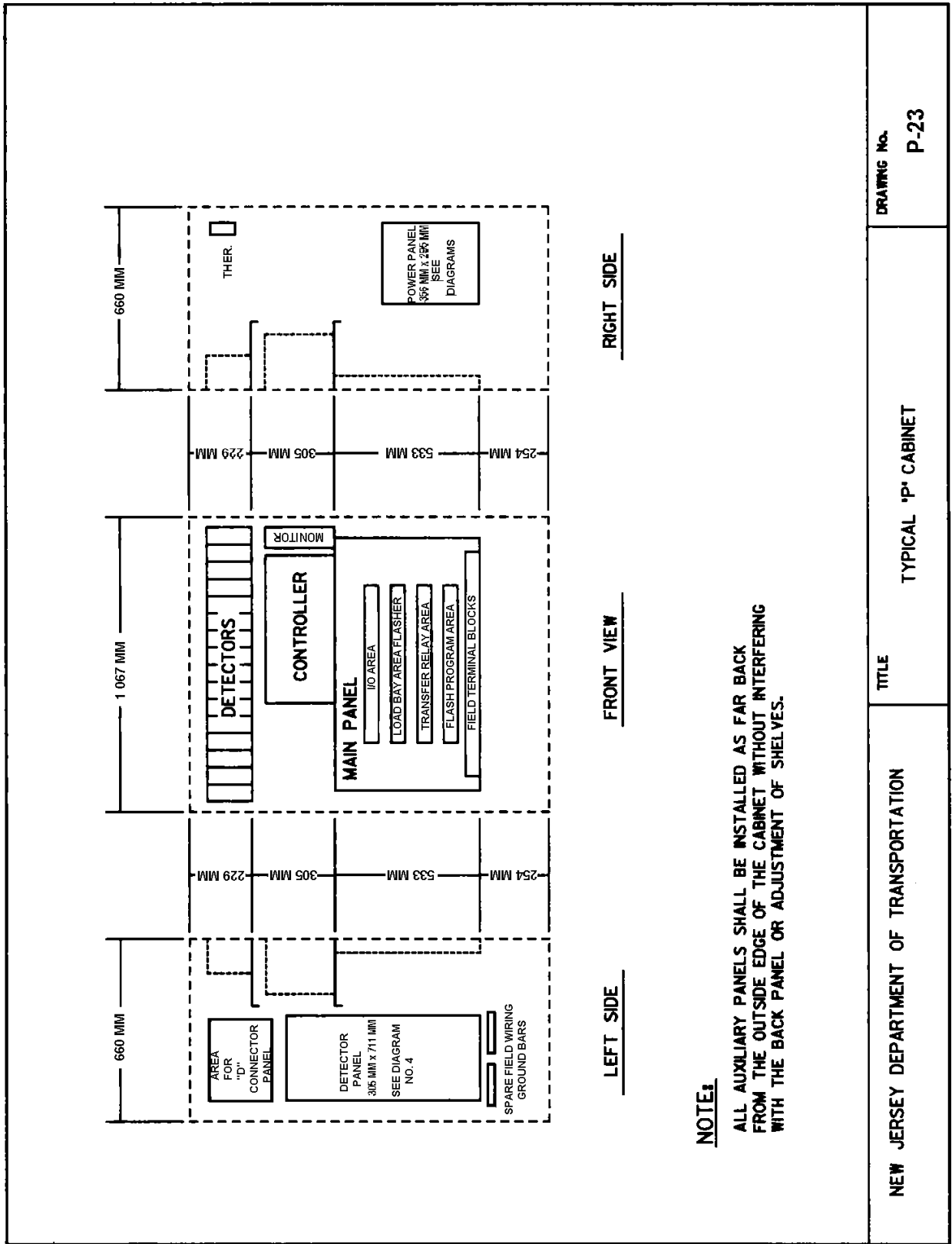

**NOTE:**

ALL AUXILIARY PANELS SHALL BE INSTALLED AS FAR BACK FROM THE OUTSIDE EDGE OF THE CABINET WITHOUT INTERFERING WITH THE BACK PANEL OR ADJUSTMENT OF SHELVES.

DRAWING No. P-23

TYPICAL 'P' CABINET

TITLE

NEW JERSEY DEPARTMENT OF TRANSPORTATION

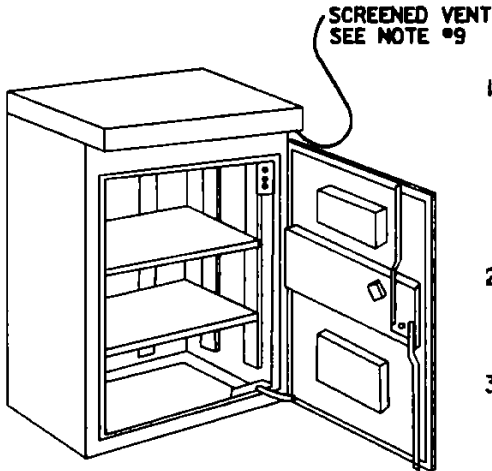

**NOTES:**

1. CABINET SHALL BE FABRICATED OF 3 MM THK. ALUM. THE CABINET TO BE MOUNTED WITH THE ANCHOR BOLT CONFIGURATIONS SHOWN. IF BASE ADAPTER PLATES ARE USED THEY SHALL BE 6 MM THK. ALUM., AND SHALL BE CONSTRUCTED TO MEET THE MINIMUM CONDUIT ENTRANCE AREA.
2. EACH DOOR SHALL BE FITTED WITH A GASKET TO INSURE DUST TIGHT & WEATHERPROOF PROTECTION UNDER ALL WEATHER CONDITIONS.
3. MANUAL CONTROL WEATHERPROOF MOMENTARY CONTACT SWITCH CONNECTED TO 1.8 M REINFORCED CORD STORED IN RECESS BEHIND SMALL DOOR IN LARGE DOOR.
4. INSTALL TWO ADJUSTABLE SHELVES.
5. SMALL DOOR SHALL BE SECURED WITH A SUB-TREASURY LOCK #0357S AND KEYED ALIKE FOR #10 AS MANUFACTURED BY THE AMERICAN HARDWARE CO. NEW BRITAIN, CONN. THE SHANK LENGTH OF KEY SHALL BE AS SHOWN. PROVIDE (2) KEYS.
6. LARGE DOOR SHALL BE SECURED WITH A CCL LOCK #15481RS WITH A MATCH #2 KEY TO BE SUPPLIED TO NEW JERSEY DEPARTMENT OF TRANSPORTATION. FOR DOOR AND LOCK DETAILS, SEE SHEET 2 OF 2.
7. WITH THE EXCEPTION OF LARGE DOOR LOCK DETAILS, ALL CABINET DIMENSIONS ARE APPROXIMATE.
8. THE LARGE DOOR MUST BE SECURED AT THE TOP AND BOTTOM OF THE CABINET BY A LOCKING BAR.
9. ALUMINUM VENT WITH SCREEN SHALL BE INSTALLED UNDER FRONT LIP ABOVE DOOR.
10. THERMOSTAT TO BE INSTALLED IN TOP OF CABINET.
11. THE MAIN DOOR HANDLE SHALL ROTATE INWARD.

**MINIMUM DIMENSIONS OF CABINET**

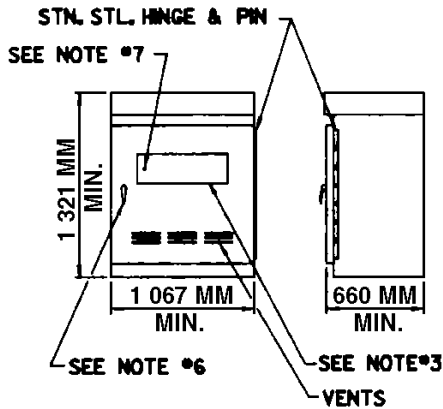

NEW JERSEY DEPARTMENT OF TRANSPORTATION	
TITLE CONTROLLER CABINET TYPE 'P' FOR FOUR AND EIGHT PHASE CONTROLLER	
SHEET 1 OF 2	DRAWING No. P-21

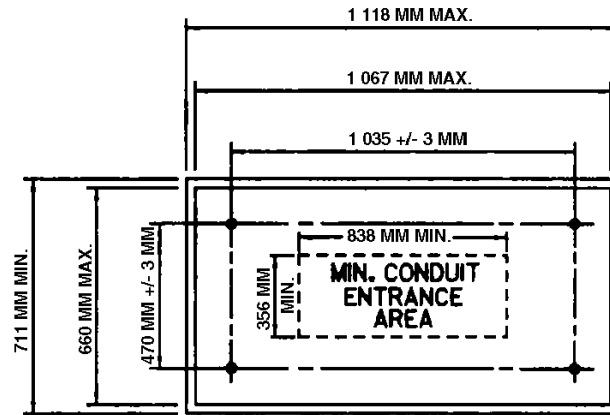
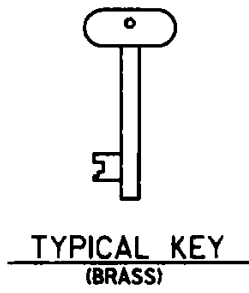

ANCHOR BOLT SLOT LOCATIONS

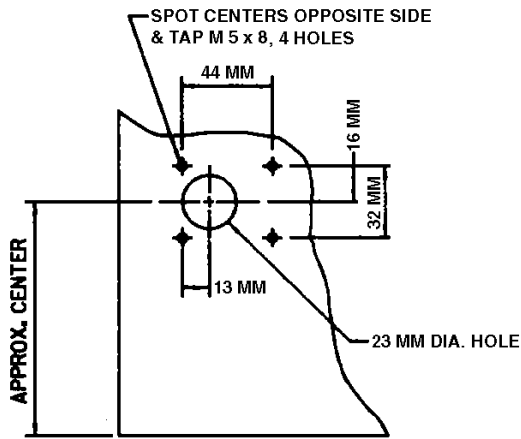

DOOR LOCK DETAIL

FIELD TERMINAL BLOCK  
50 AMP., HIGH TYPE BARRIERS

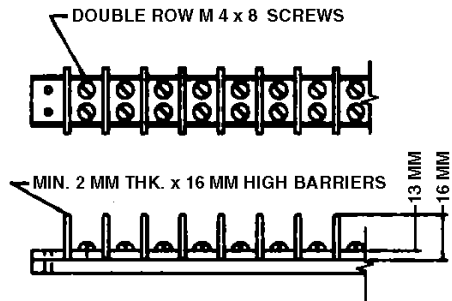

NEW JERSEY DEPARTMENT OF TRANSPORTATION	
TITLE CONTROLLER CABINET TYPE 'P' FOR FOUR AND EIGHT PHASE CONTROLLER	
SHEET 2 OF 2	DRAWING No. P-21

**ADAPTER BRACKET**

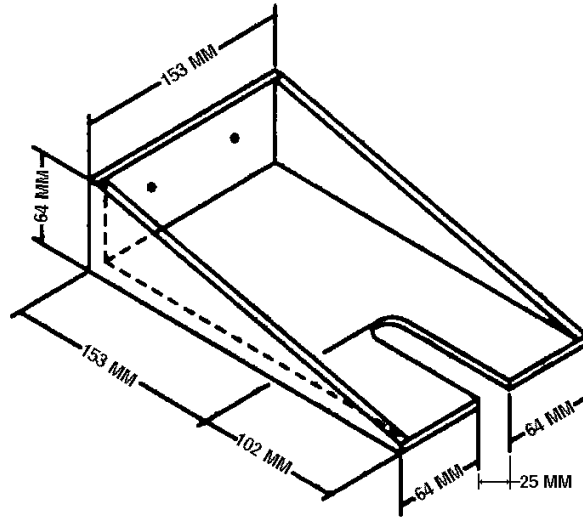

- - DENOTES 6 MM HOLES  
MATERIAL 6 MM ALUMINUM

NEW JERSEY DEPARTMENT OF TRANSPORTATION	
TITLE	ADAPTER BRACKET
	DRAWING No. P-30



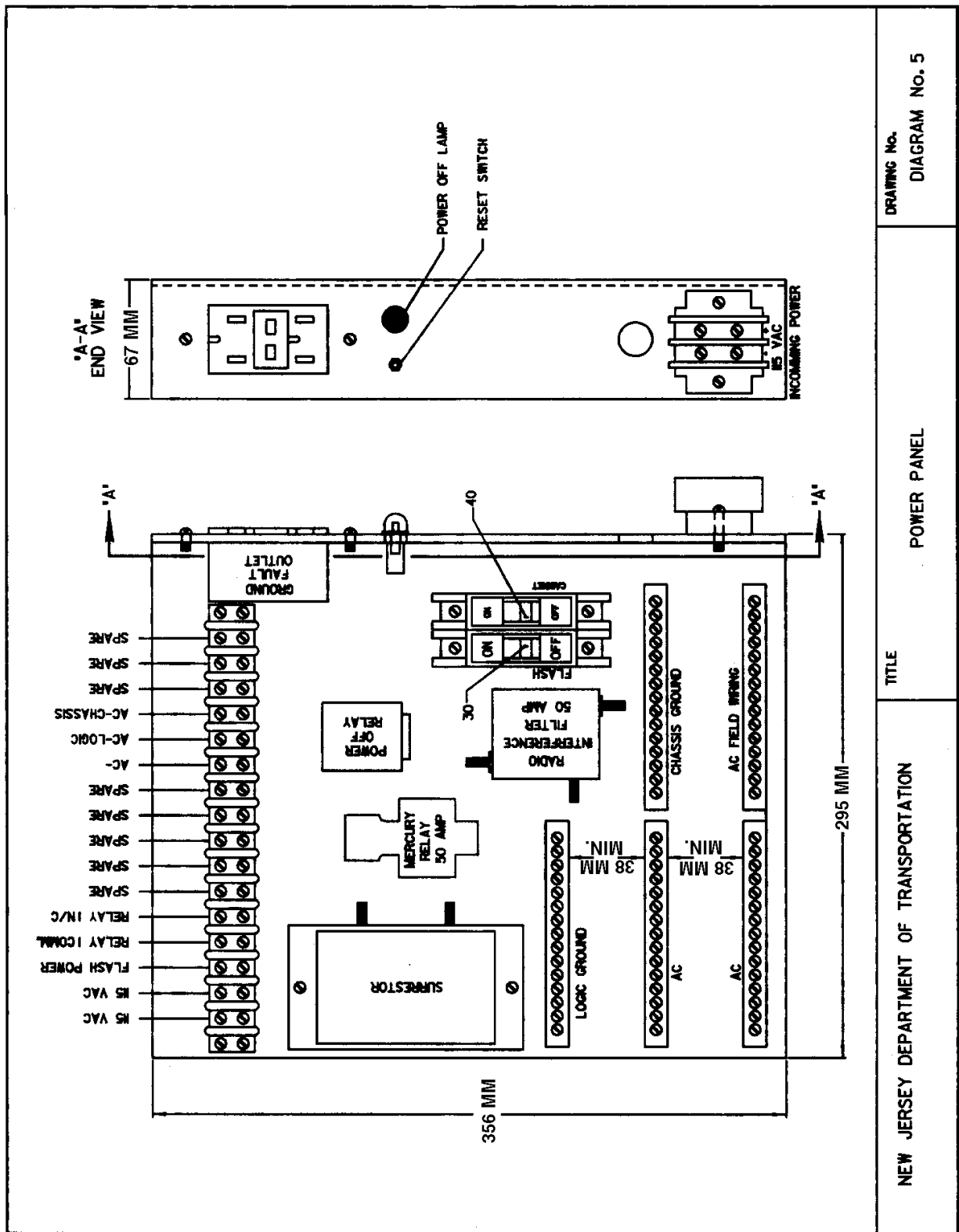

DRAWING NO.  
DIAGRAM No. 5

POWER PANEL

TITLE

NEW JERSEY DEPARTMENT OF TRANSPORTATION